



DECANTERS

Ref. 080085-89



Polypropylene decanters with collection bag



Made of resistant polypropylene.

It has been specifically designed for a quick and easy cleaning, since dirt is collected in a plastic bag. The lid closes hermetically and prevents the spread of bad smells. Its size and shape have been designed for the unit to be easily installed under the sink.

Ref. 080085 (19 L)

Specifications:

Height 465 mm • Width 400 mm • Depth 400 mm

Weight 3,2 kg • Capacity 19 L

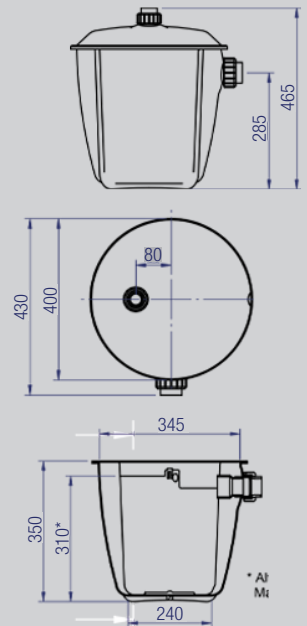

Ref. 080087 (14 L)

Specifications:

Height 345 mm • Width 350 mm • Depth 350 mm

Weight 2,2 kg • Capacity 14 L

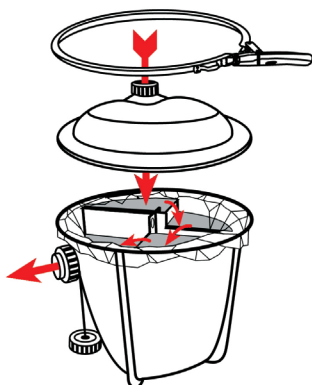
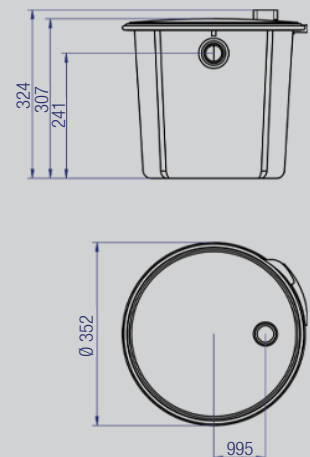

Connect the inlet to the highest chamber.

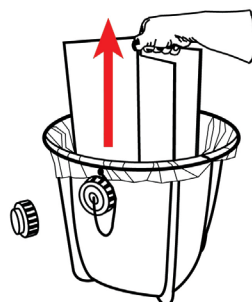

For cleaning, unscrew the outlet connector and screw on sealing cap. Skim off stagnant water and remove the separator.



Remove the outlet adapter.



Bind the bag under the outlet opening and remove waste material.

Decanter 18 L

Ref. 080086

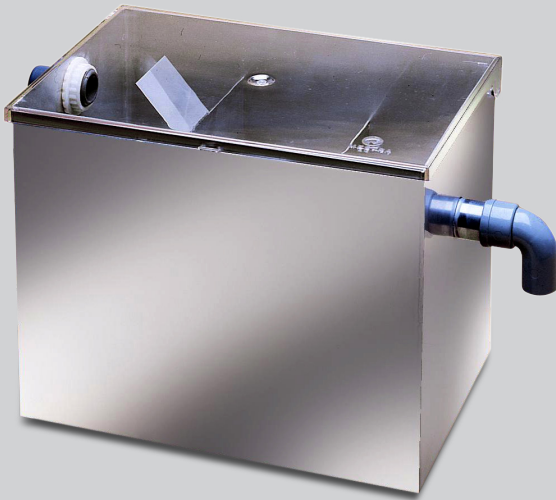

- ✓ Made of stainless steel.
- ✓ With plastic lid to prevent smells.

Specifications:

Height 290 mm • Width 450 mm • Depth 230 mm

Weight 6,5 kg • Capacity 18 L

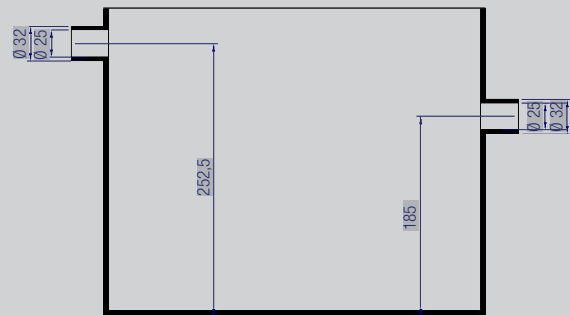

Decanter 70 L

Ref. 080089



It is made in highly resistant fibreglass with a total capacity of 70 l. and a design that allows an easy installation under the sink. It also has wheels which make its movement easier. Cleaning and emptying operations are easy because of the optimum access to the cube. This machine is supplied with all the couple nuts and accessories for its installation.

Specifications:

Height 615 mm • Width 520 mm • Depth 600 mm

Weight 10 kg • Capacity 70 L

20 unit bags

Ref. 080085-02



At **MESTRA** we are specialized in the manufacture and distribution of dental machinery and appliances. We are a Spanish company based in Bizkaia. We currently export to clients in more than fifty countries on five continents and we have more than a thousand references in our catalogue.

We have maintained a line of constant expansion since our foundation in 1945, thanks to our best qualities: the high quality of our products that have earned the ISO 9001:2015 certification by TÜV Rheinland, a close and attentive relationship with our customers, and a constant technical innovation in the design of our products.

Our design philosophy is based on three fundamental pillars: the needs of our clients, the observation of the techniques used in dental laboratories and our more than 77 years of experience providing creative and contemporary solutions to the daily problems of professionals in the sector.

Do you want to take a virtual visit to our training and exhibition center?

Contact us and we'll show you!



Talleres Mestraitua SL
(+34) 944 530 388
info@mestra.es - www.mestra.es
48150 SONDIKA (Spain)

